

Operators Guide

DUO

Direct Thermal Printer

Revision 4 – September 2004
Copyright Blazepoint Ltd. 2003 - 2004



Safety Information

- **WARNING! Potential Shock Hazard**
Always follow basic safety precautions when using this printer to reduce risk of injury from fire or electric shock.
- Use only a grounded electrical outlet when connecting the printer to a power source.
- Unplug the printer from the wall outlet before cleaning.
- Do not install or use this printer near water.
- Do not spill water or other liquid directly onto the printer.
- The printer is not suitable for outdoor use without suitable protection.
- Keep clear of moving parts while the printer is operating.
- Do not operate the printer with any of the protective covers removed.
- Refer servicing only to qualified personnel.
- The printer is not explosion proof and is therefore not suitable for use in hazardous environments in proximity to flammable solvents or gases.

Operating Precautions

- Clean the outside of the printer by wiping with a dry cloth or a cloth soaked in detergent solution and squeezed out thoroughly. Never use strong solvents.
- Place the printer on a secure level surface. Avoid locations subject to vibration and direct sunlight.
- Use only approved media supplies.
- Do not store thermal paper supplies in locations with direct sunlight, high temperature, high humidity, or high dust or gas levels as this may cause degradation of print quality.
- Do not probe the printer's operating parts with sharp or metallic objects.
- Do not allow abrasive dust particles to enter the printing mechanism since this will lead to reduced printhead life.

Copyright © 2003 - 2004 Blazepoint Ltd. All rights reserved.

Printing History

Revision 1, 27th February 2003

Revision 2, 29th July 2003

Revision 3, 25th February 2004

Revision 4, 10th September 2004

DUO Printer Operators Guide

Safety Information	2
Operating Precautions.....	2
Introduction	4
Related Documents	4
Ordering Information.....	4
Installation & Connection.....	5
Power Supply	5
Data Interface Connections	6
RS232C Serial Data Interface.....	6
USB 1.1 Interface	6
Centronics Parallel Data Interface	7
Cash Drawer Interface.....	7
Media Loading.....	8
Front Panel Controls	9
Control Buttons.....	9
Feed	9
Pause	9
Cancel	9
Indicator LEDs.....	10
Ready LED (Green).....	10
Pause LED (Amber).....	10
Error LED (Red).....	10
Test Printouts	10
Windows Drivers and Software Applications.....	11
Windows Drivers	11
BlazeConfig Utility	11
Label Design Software	11
Cleaning and Maintenance.....	12
General Cleaning.....	12
Sensor Cleaning.....	12
Printhead Cleaning.....	12
Troubleshooting.....	13
Stock Conversion Specifications	14
Label Conversion.....	14
Ticket Media Conversion (black mark).....	15

The DUO range of printers is designed in the United Kingdom by:

Blazepoint Ltd.
2 Tower Estate
Chalgrove
Oxford
OX44 7XZ
United Kingdom

Tel: +44 (0) 1865 892 030
Fax: +44 (0) 1865 892 031
Email: sales@blazepoint.co.uk
Web: www.blazepoint.co.uk

Blazepoint products are subject to continuous development and improvement, and consequently may incorporate minor changes from the information contained in this manual.

Installation & Connection

The printer can be installed in any normal office or factory environment. No special wiring or cooling is required, but a minimum 25mm (1 inch) clearance all round the printer is required for proper ventilation. Whilst the printer can be used in dusty environments this will reduce its operating life. Regular cleaning is recommended to ensure correct operation and maximum service life.

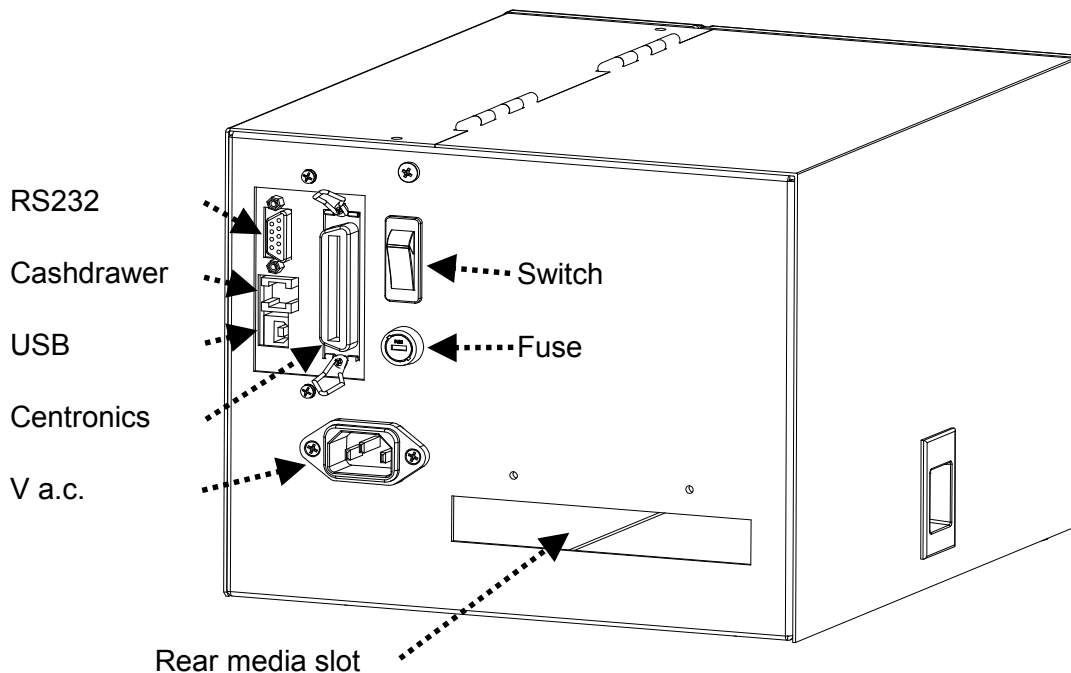

Figure 1

Power Supply

Line voltage is 90-264Vac, 47-63Hz. Details are shown on the rating plate at the rear of the unit. After confirming supply requirement on the rating plate, connect the IEC socket end to the mating connector on the rear of the printer, Figure 1.

The power supply is a switch-mode unit and is fully protected against short circuit and other load faults. Input fuse rating is 6.3AT. Do not use any other type of fuse in this unit.

WARNING: This equipment must be earthed.

Data Interface Connections

The printer is fitted with an RS-232C serial port, a Centronics parallel port, a USB 1.1 port and a Cashdrawer port as standard. All ports may be connected and the printer will select the active port automatically provided that they are not used simultaneously.

RS232C Serial Data Interface

The serial port is a standard 9-way DCE port. PC to Printer cables can be obtained from Blazepoint (Blazepoint Part No. 4999992354), or alternatively a standard 'Straight through' cable may be used. A 'null modem' cable will not work.

Use the printer setup utility, blazeConfig, supplied on the CD, to set the baud rate, parity, data and stop bits. These must all be set to match the values used by the host computer for the interface to operate correctly. Note that in order for this application to communicate with the printer using the serial port, the standard settings of 9600,N,8,1 must be used. Switching the printer on whilst keeping the FEED and PAUSE buttons pressed will set these values until the printer is next powered off and on or reset.

Serial Port Pin Functions

Pin No	Name	Function
1	5Vdc	400mA max output
2	TXD	Data output to host
3	RXD	Data input to printer
4	N/C	
5	GND	Signal Ground
6	RDY	Handshake output to host (connected to pin 8 internally)
7	CTS	Handshake input to printer
8	RDY	Handshake output to host (connected to pin 6 internally)
9	N/C	

USB 1.1 Interface

The USB interface conforms to the USB 1.1 standard and may be connected to a USB 1.1 or USB 2 host port using a standard USB A – B cable. USB cables can be obtained from Blazepoint (Blazepoint Part No. ELT-300283-001). USB printing is supported on Windows 98SE, ME, 2000, XP, 2003 and later operating systems. Windows 95 and Windows NT4.0 do not support USB devices.

Centronics Parallel Data Interface

The Centronics connector is an Amphenol 36 way female type. The lead should be kept as short as possible and should not exceed 3 metres. The Centronics port is IEEE-1284 compliant and will work with any standard Centronics printer port. Check that the cable is pressed securely into the connector and locked with the wire loops. PC to Printer cables can be obtained from Blazepoint (Blazepoint Part No. 4999992355), or alternatively a standard PC printer cable may be used.

Parallel Port Pin Functions

Pin No	Name	Function
1	nStrobe	Data strobe
2-9	Data1-8	Data input to printer
10	nAck	Acknowledge handshake
11	Busy	Printer busy
12	PError	Paper error
13	Select	BiDi control
14	nAutoFeed	BiDi control
15	N/C	
16, 17	0V	0V return
18	5Vdc	400mA max output
19-30	0V	0V return
31	N/C	
32	nFault	Printer fault condition
33-35	N/C	
36	nSelectIn	BiDi control

Cash Drawer Interface

The cash drawer port can drive a cash drawer with the industry standard RJ11 type connector. Two cash drawers can be driven using a standard 'Y' cable. This port may also be used to control other external equipment such as applicators and print switches.

Cash Drawer Driver Pin Functions

Pin No	Name	Function
1	0V	0V reference
2	CD1-	Drawer 1 driver (active low)
3, 4	+24V	1A max total current, 100mA max average current
5	CD2-	Drawer 2 driver (active low)
6	Sense	Drawer-open sense (active high)

Media Loading

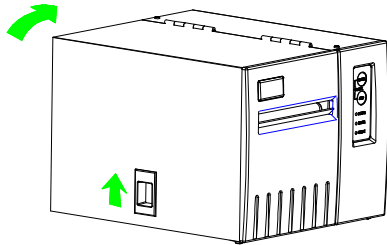

1. Lift the latch and open the paper compartment cover.

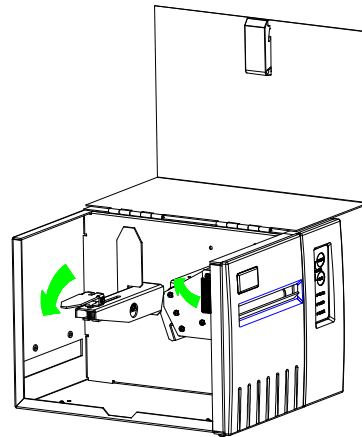

2. Lift the head-locking lever to the horizontal position and lower the outer paper-roll guide.

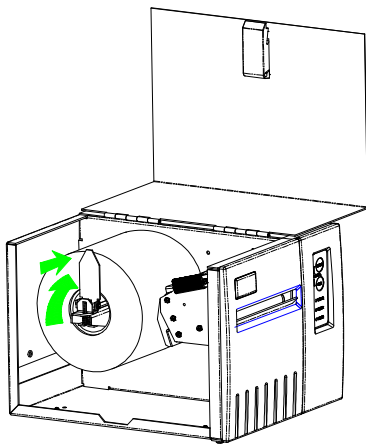

3. Slide the paper roll onto the hanger and raise the outer roll guide.

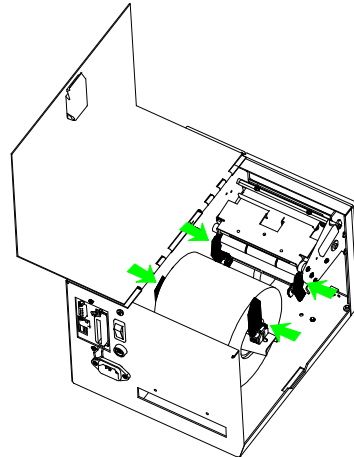

4. Adjust the roll guides and the paper guides so that the paper path is straight and in the correct position.

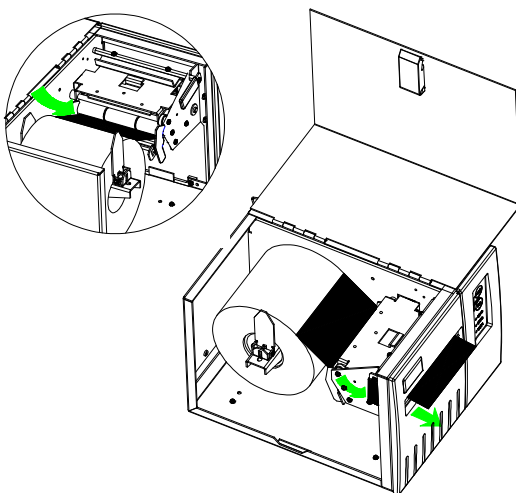

5. Feed the media *under* the white roller, under the print head and out through the front aperture.

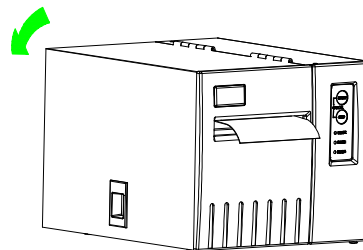

6. Swing the head-lock lever down to lock the head, then close the paper compartment cover.

If new media is loaded into the printer with different backing material or black mark, it may be necessary to adjust the media sensor sensitivity. To start this procedure, hold the PAUSE key in for 3 seconds. When the media starts to feed release the PAUSE key. The printer will feed out 3 labels / tickets and stop at the top-of-form position.

Front Panel Controls

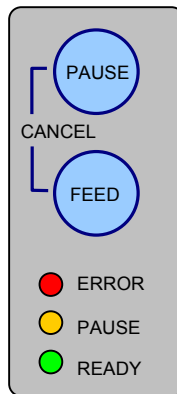

Control Buttons

Feed

- In normal operation, pressing Feed will feed one label.
- If a fault condition is indicated (Red LED), press Feed to clear the fault and restart operation.
- In Demo mode, pressing Feed will send the current demo file to the printer.
- Holding Feed at power-on will cause the self-test label to be printed out.

Pause

- In normal operation, press and release the Pause button to pause a long print run. Press Pause again to restart printing.
- Press and hold Pause for 3 seconds to calibrate the label sensor.
- In Demo mode, press Pause to cycle through the available demo files.
- Holding Pause at power-on will cause the printer to enter Hex-dump mode. All data sent to the printer is printed in HEX and ASCII, rather than being interpreted.

Cancel

Press the Feed and Pause buttons together, pressing Pause slightly before Feed to avoid inadvertently feeding a label.

- In normal operation, pressing Cancel will terminate all printing and clear the print buffer.
- If Demo files are available, pressing Cancel will toggle Demo mode on and off.
- If a blazeFilter is present, pressing Cancel will reload and restart the filter.
- Holding Feed and Pause at power-on will cause the printer to enter Safe mode. In this mode, the serial port is set at 9600,N,8,1, no fonts are loaded except the built-in system font, no Autoexec file is processed, no demo files are loaded, no filter is loaded. Press Feed and Pause again to exit safe mode.

Note: To use one of the power-on modes, make sure the printer has been switched off for at least 5 seconds, and that none of the LEDs are lit.

Indicator LEDs

Ready LED (Green)

- This is a steady green when the printer is operating, and flashes when the printer is processing data.

Pause LED (Amber)

- In normal operation this indicates when the printer is in the paused state.
- In Demo mode, the number of flashes indicates the file number of the current demo file.
- In Hex-dump mode, the LED flashes continuously.

Error LED (Red)

- In normal operation this LED should be off. Any activity indicates an error or warning condition.

Red LED flash pattern	Error / warning indicated
Even flashing	Head open/unlocked
2 flashes, short pause	Paper out
3 flashes, short pause	Ribbon out
4 flashes, short pause	Rewinder full
5 flashes, short pause	Cutter jammed
1 brief flash, long pause	Ribbon-low/Rewinder-high (warning only)
2 brief flashes, long pause	Serial input buffer overflow (warning only). Check the serial port handshaking.
3 brief flashes, long pause	Over-temperature condition (warning only). Printing will restart automatically when the temperature has fallen.
Constant on	Power supply or mains input undervoltage. May be cause by a temporary dip in mains supply.

Test Printouts

To printout the self-test label / ticket, first switch the printer off and wait 5 seconds. Now hold the FEED key in while switching the printer on. When the self-test image begins to print release the FEED key.

For debugging of data being sent to the printer there is a HEX dump mode. To enter this mode of operation, first switch the printer off and wait 5 seconds. Now hold the PAUSE key in while switching the printer on. When only the green light is illuminated release the PAUSE key. Now any data sent to the Serial, Parallel or USB port will be printed on the media in HEX and ASCII. Press Cancel (Feed and Pause) to exit HEX dump mode.

For both these printouts, the media should be centred and at least 85mm wide. If the label sensor is calibrated correctly, the printing will skip over label gaps.

Windows Drivers and Software Applications

The Windows printer drivers and blazeConfig are included on the CD supplied with the printer. The latest versions can be downloaded from www.blazepoint.co.uk.

Windows Drivers

The Windows driver enables the DUO printer to be used with any application running under Windows NT4.0, 95, 98, ME, 2000 and XP. This includes a variety of labelling programs as well as the usual range of word processing and desktop publishing packages, spreadsheets, databases, etc. These fully-featured drivers support most of the facilities offered by the printer.

BlazeConfig Utility

blazeConfig will run under Windows NT4.0, 95, 98, ME, 2000 and XP. It includes a suite of utilities designed to make it easy to customize your printer to suits a wide variety of applications. Facilities include:

- Printer configuration
- Download fonts, images and autoexec files
- Update the printer firmware
- Label capture for standalone mode
- blazeFilter – the input data filter
- Diagnostic tools
- Test labels
- Save & restore printer settings

The blazeConfig distribution files always include the most recent release of the printer firmware. The latest version of blazeConfig can be downloaded from the Blazepoint website.

Label Design Software

“NiceLabel for Blazepoint SE” is an intuitive Windows label design program. It uses the Windows printer drivers to their best to produce excellent results. A free copy of this application is included on the CD supplied with the printer. If you require more advanced features, an upgrade path is available.

Cleaning and Maintenance

For maximum operating life and best print quality the printer should be regularly cleaned. All loose paper particles should be blown away, and the print head, rollers, label sensor and label guides cleaned of adhesive and paper residues. Cleaning should be carried out after every 2km of printing, 10,000 labels/tickets, or monthly, whichever is most frequent.

General Cleaning

The external casing of the printer can be cleaned with a cloth soaked in soapy water and squeezed out thoroughly. The printer must be switched off during any cleaning operation. Take care not to allow liquid to penetrate the internal parts.

Sensor Cleaning

Using a small soft brush, remove all paper dust and debris from the label sensor. Take care not to bend the optical sensor elements out of alignment.

Printhead Cleaning

Deterioration in print quality may be due to an accumulation of dirt or adhesive residue on the printhead. To clean the printhead, proceed as follows:

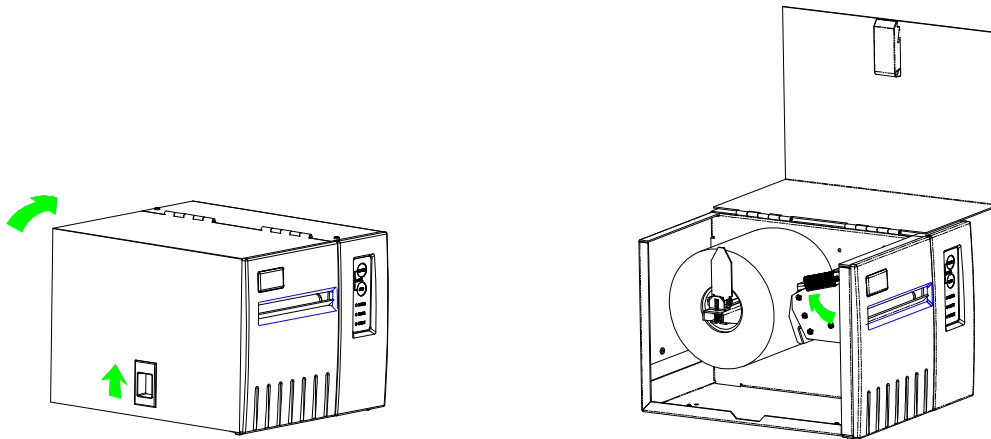

1. Lift the latch and open the paper compartment cover.
2. Lift the head-locking lever to the horizontal position.

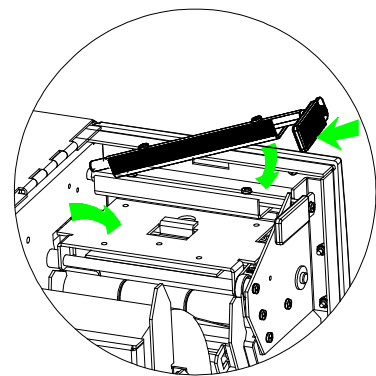
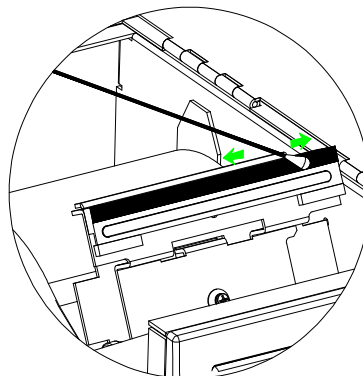
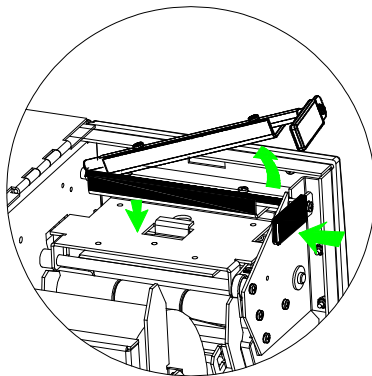

3. Press the head-locking bar inwards to disengage from the side plate, then lift up and remove.
4. Allow the printhead to swing upwards. Clean carefully according to the instructions below.
5. Swing the printhead down, then replace the locking bar, pressing inward to allow it to enter the lock.

The active print element is the thin black line across the printhead which reflects light if viewed under a bright light source. Using a cotton bud and thermal printhead cleaner (isopropyl alcohol), wipe the print element 4 or 5 times and allow the solvent to evaporate. Re-examine the printhead and repeat as necessary until the reflection is even along the entire length of the print element.

Troubleshooting

Symptom	Check
No lights on front panel	Check that printer is plugged in and switched on. Check mains fuse on rear panel.
No response to communications	Check serial port settings (serial only). Check that the correct cable type is in use. Check that cable is securely plugged in at both ends. Check that the network settings are correct, referring to your network administrator (Ethernet & WiFi only). Try hex dump mode.
Error light flashing	Check front panel flash codes, correct the fault then press FEED to restart the printer.
Paper Empty error when paper is loaded	Press and hold PAUSE to recalibrate the label sensor. Check that paper passes <i>under</i> the white roller. Check that paper guides are set correctly and that the paper passes through the paper sensor.
PAUSE light is on	Press PAUSE button to toggle pause on and off.
Printing blank labels	Check that direct-thermal labels or tickets are in use. Plain paper media will not work. Use the printer self-test to check printability. Check that a very low heat setting has not been selected by mistake.
Poor print quality	Check that the printhead is clean. Check that the printer is set for direct-thermal mode. Use appropriate speed and heat settings for the media.

Stock Conversion Specifications

Print quality is dependent not only on the DUO printer, but also on the quality of the label or ticket stock. It is very important to select the correct paper type to ensure that both print quality and head life are optimised. Blazepoint recommend the use of top-coated thermal paper for best print quality and head life.

Label Conversion

The roll hanger is designed to hold stock wound print-surface outwards onto a 44mm inside diameter core. Larger and smaller cores can also be accommodated in the range 38-76mm.

Label stock is aligned using an optical sensor which looks through the stock and detects the change in optical transmission. This sensor is referred to as the *transmissive* or *gap/hole* sensor.

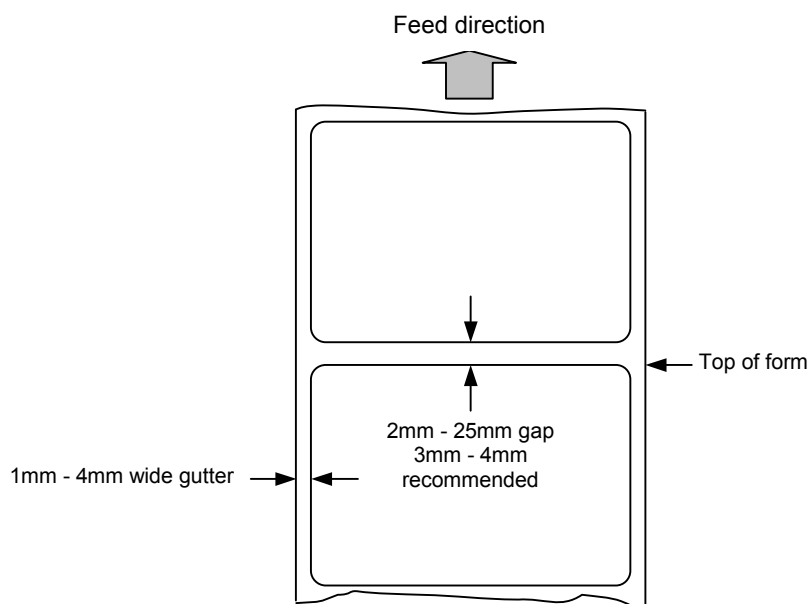

Ticket Media Conversion (black mark)

Tickets are aligned using a black mark printed on the reverse side of the ticket media, to be detected by the *reflective* or *black mark* sensor. The black mark must conform to the dimensional limits shown below. For optimum sensor performance, it is recommended that the black mark bar be extended across the full width of the ticket.

Where tickets are perforated for fan-folded presentation, it is recommended that the black mark be positioned at the end of the ticket as shown.

